

## 被子包边机

## Quilt Edge Binding Machine

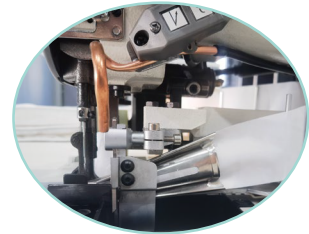

### 适用范围

棉服、夏凉被、春秋被、棉被等被褥的包边缝纫工艺。

### 机器特点

- 单针综合送料，实现对物料切、包、缝一次成型。
- 侧切刀右边加大的排料口和气动辅助排料设计，使切边时产生的废料排放更顺畅。
- 特殊的交替压脚、机针、送布牙和包边装置四同步送料结构，以达到在车缝直线和转角位置时产品无褶皱、无移位的包边效果。
- 针杆微油处理技术，使的缝制产品更干净、无污染。
- 吹风装置起到冷却切刀和吹风排料的作用。
- 可选配对折/回折拉筒，以满足不同需求包边工艺。
- 可选配吸尘箱/定制加大辅助桌，减少操作者劳动力，使的缝制更轻松、便捷。

### Application

Designed for edge binding processes of quilts such as cotton quilts, summer quilts, spring and autumn quilts, and other bedding items.

### Features

- Features of single-needle compound feed, achieving cutting, binding, and sewing in one seamless operation.
- Enlarged right-side waste discharge port with pneumatic waste discharge assistance ensures smoother disposal of waste generated during edge cutting.
- Special four-synchronized feeding structure, including alternating presser foot, needle, feed dog, and binding attachment, ensures no wrinkles or misalignment during straight-line or corner sewing for a flawless binding effect.
- Micro-oil needle bar treatment technology ensures cleaner, pollution-free sewing results.
- Blowing device cools the cutting blade and assists in waste discharge.
- Optional folding/return folding attachment to accommodate various binding process requirements.
- Optional dust collection box or customized enlarged auxiliary table, reducing operator fatigue and making sewing operations easier and more convenient.

## 被子包边机 Quilt Edge Binding Machine

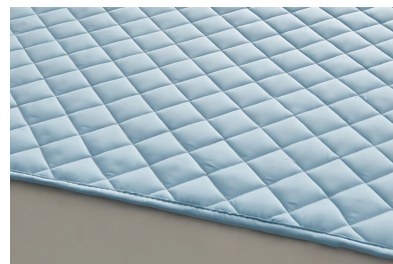
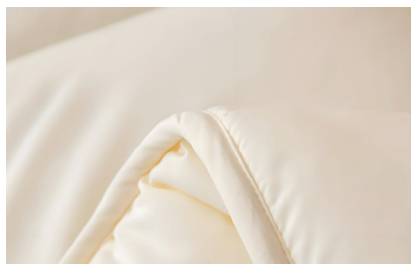

### 主要参数 Parameters

型号: Model:	GOA-IS,1510AE-7-TBL		
机针: Machine Needle:	DP×17MR,18-23#	梭芯直径: Bobbin Core Diameter:	28mm
最大针步: Max. Stitch Length:	9mm	压脚最大提升高度: Presser Foot Lifting Height:	16mm
可缝制最大厚度: Maximum Sewing Thickness:	压缩后10mm以内	最高缝制速度: Maximum Sewing Speed:	2000RPM
电压: Voltage:	AC 220V, 50/60HZ	功率: Power:	750W
气压: Air Pressure:	0.5MPa	机器尺寸: Dimension:	1200×550×1350mm

### 选配 Optional



1200×900×750mm  
可选配吸尘箱  
Optional dust collection box

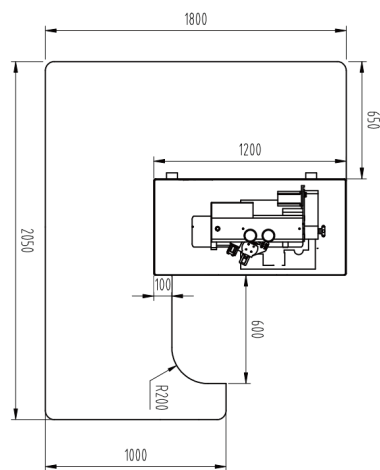

2050×1800×(700-730) mm  
定制加大辅助桌  
Customized enlarged auxiliary table

### 天津再登高智能制造有限公司

地址: 天津宝坻经济开发区天宝南环路3号B楼  
邮箱: sales@getonagain.com  
网址: www.GetonAgain.com

**400-166-8581**

### Tianjin GetonAgain SM Co., Ltd.

Address: Block B, No.3, Nan Huan Road, Economic Development Zone,  
Baodi, Tianjin, China.  
Email: sales@getonagain.com www.GetonAgain.com